

trouble shooting  
target flight  
adjustment and  
maintenance  
manual

*Western*<sup>®</sup>  
self loading  
electric skeet trap  
model V1574A



GENERAL - V1574A AUTO-LOADING SKEET TRAP

- CAUTION: A. Before making any adjustments on trap, pull master switch (X116W) to off position, and pull trigger (V57) to fire trap.
- CAUTION: B. Always be sure to pull each master switch (X116W) to off, and pull triggers (V57) to release carriers at end of shoot to leave traps in fired position.
- CAUTION: C. When a target is thrown from this trap with the power off, the carrier will throw the target then start to back up. If the switch (X116W) is turned to the on position while the carrier is in its rearward motion, the motor will reverse itself and pull the carrier backward, damaging target stop finger (V215) and target feed finger (V209A).
- CAUTION: D. When operating the off and on switch (X116W) for any reason, always be sure the carrier is completely stopped before turning switch to the on position.
- CAUTION: E. When changing position of carrier rail on carrier to take curve out of targets, (Page 16, Item "D"), always support carrier underneath with other hand when loosening or tightening screws to prevent springing carrier.
- F. Do not remove targets from cartons until ready to load magazine. Check for broken or cracked targets when loading magazine.
- G. Once a month check to be sure bolts holding trap to plank and plank to base are tight.
- H. Occasionally check for badly worn carrier rail assembly (V32W). A worn carrier rail may be reversed for further use.

## CONTENTS

1. Target flight, page 15.
2. Target flight adjustments, page 15.
3. Oiling, page 17.
4. Trouble shooting problems self loading electric skeet trap model V1574A.
  - A. Trap fails to cock when master switch (X116W) at rear of trap is turned on, see page 3.
  - B. Trap cocks but fails to release when button is pressed, see page 5.
  - C. Carrier continues to revolve without stopping in cocked position, see page 7.
  - D. Target fails to drop from magazine onto trap feed shelf (203W) when carrier is in cocked position, see page 9.
  - E. Targets double feed (more than one target drops from magazine onto trap feed shelf (V203W) causing broken targets when carrier is released, see page 9.
  - F. Trap throws several broken targets immediately after magazine has been loaded, see page 9.
  - G. Trap throws continuous broken targets, see page 11.
  - H. Trap throws large percentage of broken targets, see page 14.

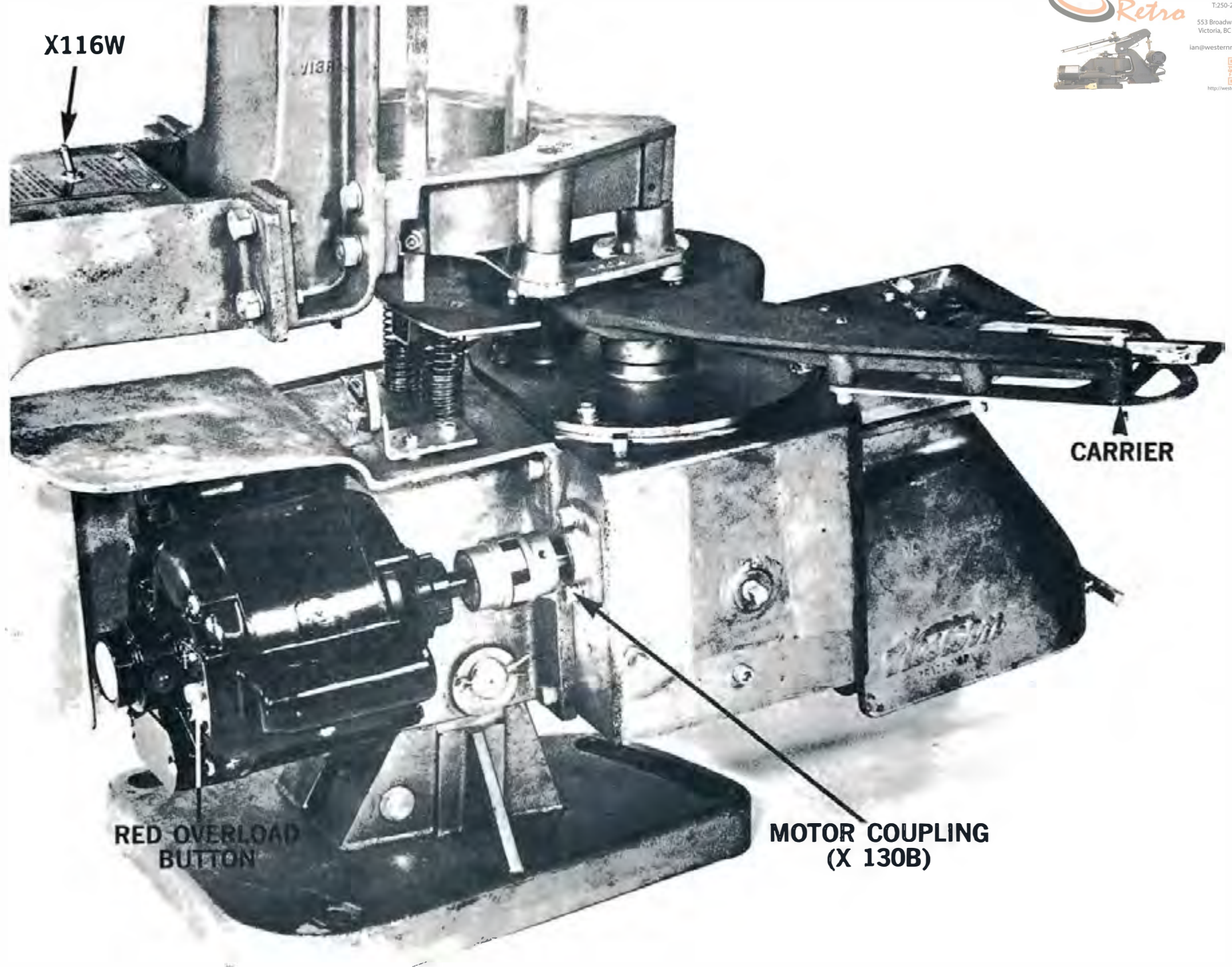

**X116W**

**CARRIER**

**RED OVERLOAD  
BUTTON**

**MOTOR COUPLING  
(X 130B)**



PROBLEM: Trap fails to cock when master switch (X116W) at rear of trap is turned on.

CORRECTION:

1. Check to see if motor is running. IF NOT
  - A. Check power supply to trap house.
  - B. Check to see if power connection into left side of trap is screwed in tight.
  - C. Press in red overload button on motor, overload may have shut motor off due to low voltage or trap being jammed.
  - D. Revolve motor coupling one or two turns to be sure motor revolves freely.
2. Check to see if motor is running. IF MOTOR IS RUNNING
  - A. Check to see if carrier is in neutral position (just to right of forward position.) If it is, move carrier to forward position (counter clockwise) by hand. DO NOT attempt to completely cock trap by hand, just move carrier to most forward position and motor will cock trap.
  - B. Check for failure or slippage of motor coupling (X130B). Tighten or replace as indicated.

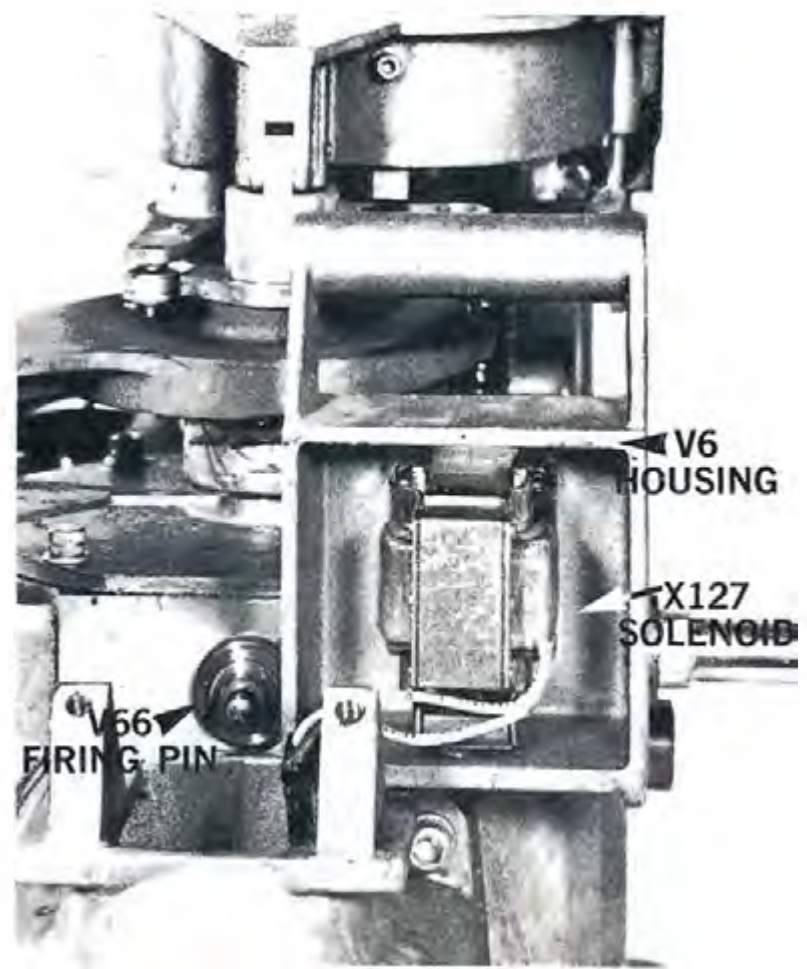

PROBLEM: Trap cocks but fails to release when release button is pressed.

CORRECTION:

1. Pull up on mechanical release trigger (V57) at left rear of trap. -  
IF TRAP RELEASES MECHANICALLY.
  - A. Check for broken wire in release cord. Check release cord and button by trying on another field. Replace cord and button if indicated.
  - B. Check release solenoid (X127) by removing two screws (V161W) just in back of carrying handle at front of trap, and lift solenoid housing (V6) away from trap. Press and release electrical release button. If solenoid is not activated by release button, replace solenoid. Be sure master switch is off and carrier is uncocked before removing housing.
2. Trap does NOT release either with release button or trigger (V57).
  - A. Check for broken main spring (V40W) by reaching under housing at front of trap or by turning mainspring adjusting screw (X42). (If screw turns loosely, spring is broken.) If spring is broken, remove broken parts, then release carrier by pulling up on trigger (V57) and manually positioning carrier in a forward position. Install new spring.

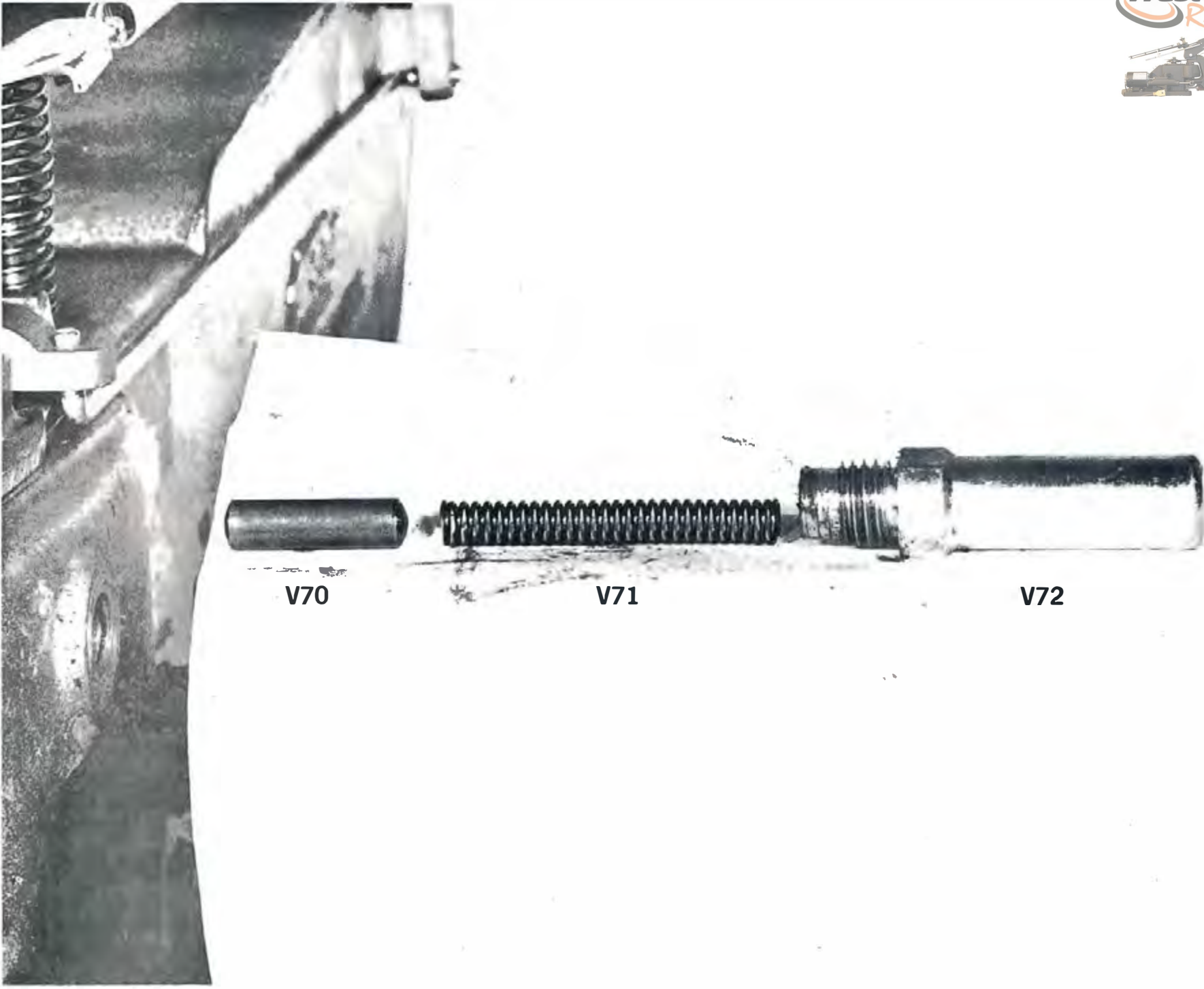

V70

V71

V72



**PROBLEM:** Carrier continues to revolve without stopping in cocked position.

**CORRECTION:**

- A. Check to see if person pressing release button is holding button depressed after target has been thrown.
- B. Turn off master switch and unload targets from magazine, disconnect release cord (not power supply on left hand side of trap.) Turn master switch on. If trap now works properly by using mechanical release trigger (V57) check for electrical short in release cord or button. A simple way to check cord and button is to try cord on another field.
- C. Check release solenoid (X127) by removing two screws (V161W) just in back of carrying handle at front of trap and lift solenoid housing (V6) away from trap. Press and release electrical release button if solenoid is not activated by release button replace solenoid. Before replacing solenoid housing (V6) check for free movement of firing pin (V66). This is the pin that is pressed by the solenoid when trap is released. (Picture, page 4.)
- D. Remove sear plunger bushing (V72) on left front of gear box (being careful not to drop sear plunger (V70) inside gear housing) and check for broken spring (V71).

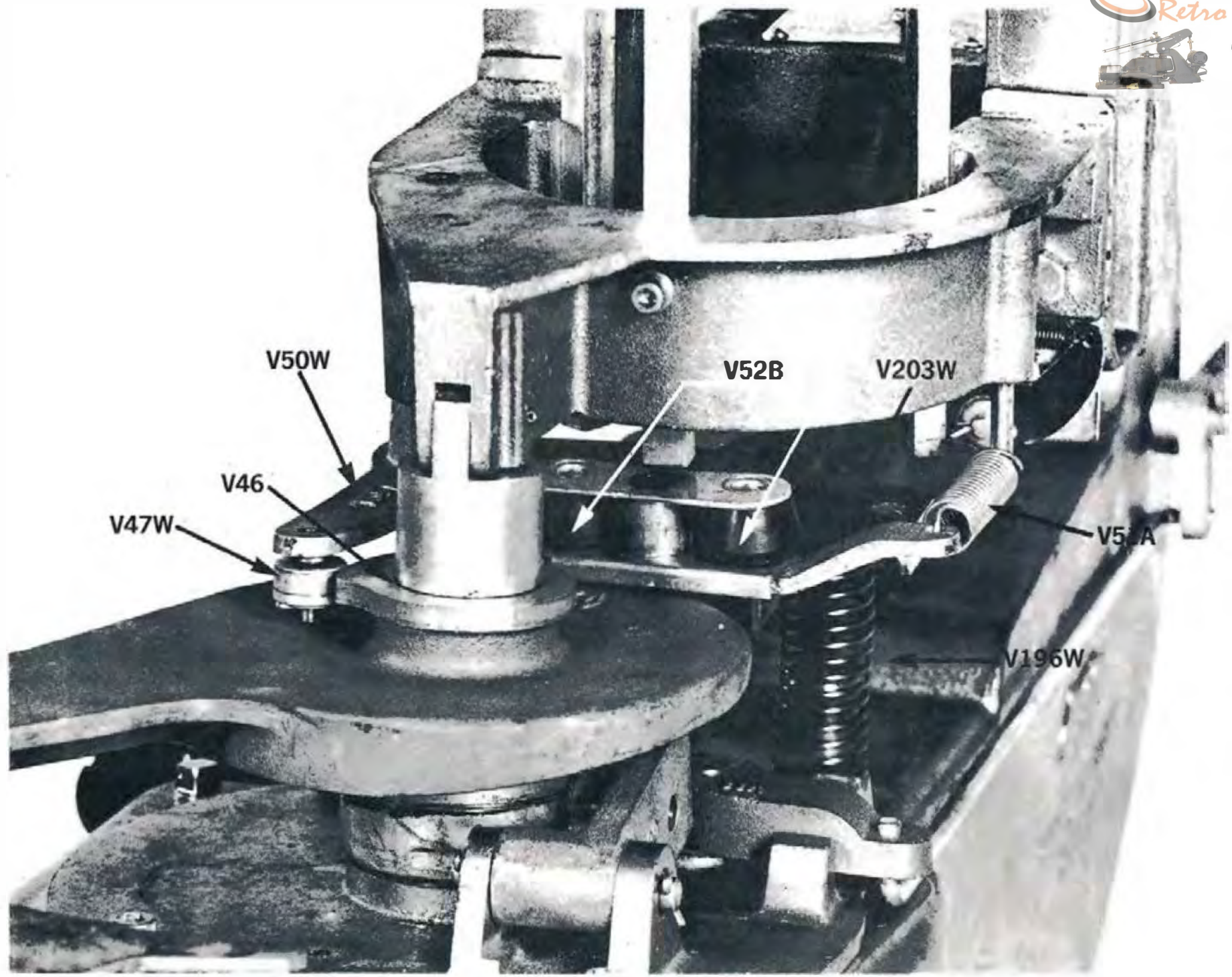

Problem:

Trap throws several broken targets immediately after magazine has been loaded.

Correction:

- A. Check for sluggish movement of target feed shelf (V203W). With carrier in fired (forward) position, and with magazine fully loaded, press down on target feed shelf (V203W) and release. Shelf must return briskly to its highest position. If shelf is sluggish in its upward motion, check for broken feed shelf lifting springs (V196W); also clean and oil guide rods and bronze bushings. Recheck for proper movement.
- B. Check for worn rubber escapement cushions (V52B). Turn both cushions to present a new surface in contact with targets or replace if badly worn.
- C. Check condition of escapement lever spring (V51A), and replace if tension is light.

Problem:

Targets double feed (more than one target drops from magazine onto target feed shelf (V203W), causing broken targets when carrier is released).

Correction:

- A. Check for broken escapement lever spring (V51A) on lower left hand side of magazine.
- B. Check for worn (rubber) escapement cushions (V52B); turn both cushions to present a new surface in contact with targets or replace if badly worn.
- C. Check for broken escapement lever (V50W).

Problem:

Target fails to drop from magazine onto target feed shelf (V203W) when carrier is in cocked position.

Correction:

- A. Check for broken escapement lever assembly (V50W).
- B. Check for missing escapement cam roll (V47W) from escapement lever.
- C. Check to be certain escapement cam roll (V47W) is in contact with cam (V46), not bent and riding over top of cam.



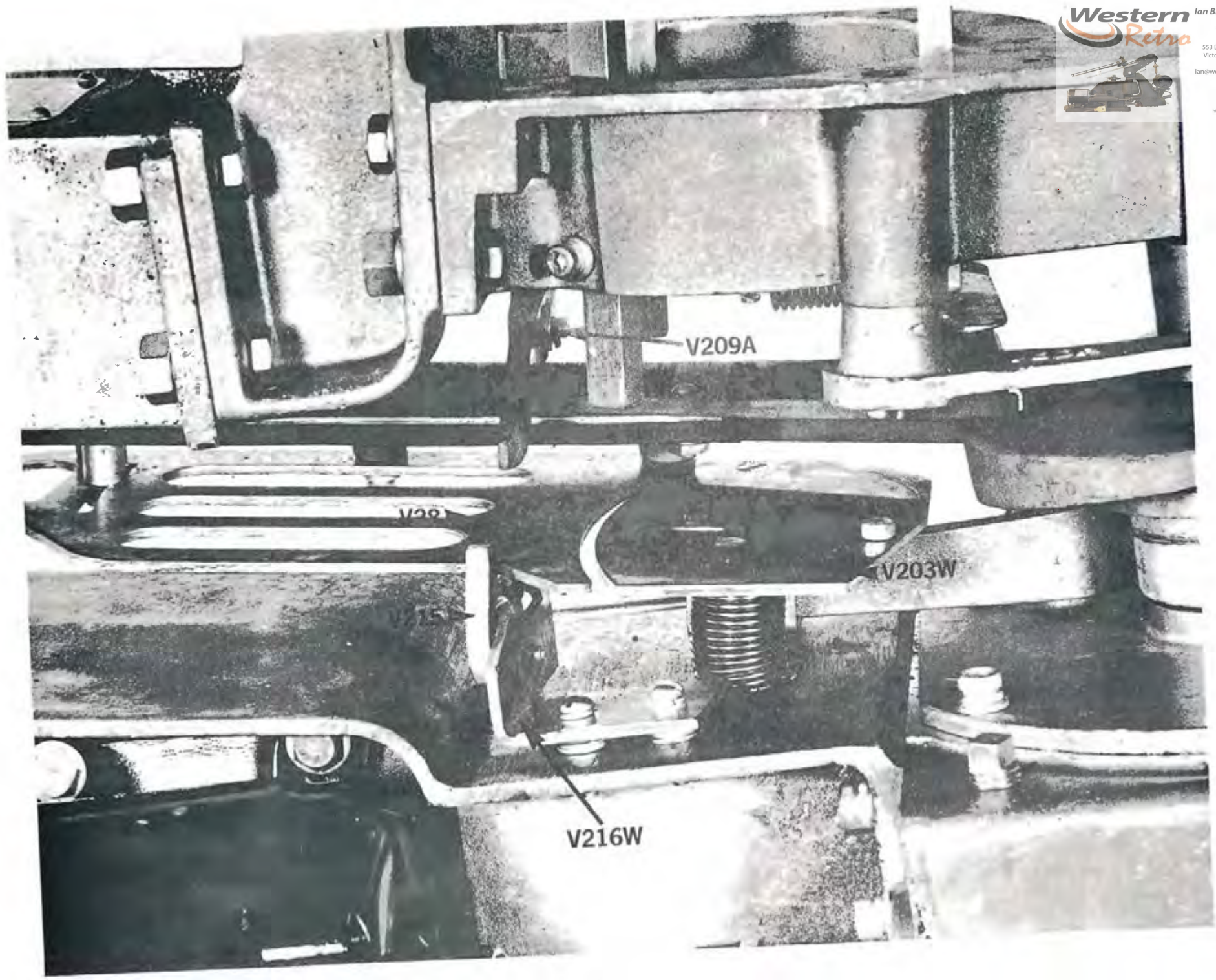



PROBLEM: Trap throws continuous broken targets.

CORRECTION:

- A. Check to be sure target is not hitting opening in house or target chute.
- B. Check for targets double feeding. See previous instructions for correction.
- C. Check for broken (fiber) target feed finger (V209A) left hand side of trap or broken finger spring. When replacing or adjusting finger, the tip of finger should be about  $9/16$ " above carrier plate (V28) in cocked position. Check with a target to see that the tip of finger clears top of target rim by  $1/16$ " to  $1/8$ ". (If too low and against target rim, it will cause target to jump over guide button on feed shelf (V203W). To adjust finger to correct height, loosen the bolt and screw holding the feed finger bracket and tap to properly position the tip of feed finger. Retighten screw and bolt.
- D. Check for incorrect adjustment of target feed finger (V209A). See item "C" above for proper adjustment.
- E. Check for broken (fiber) target stop finger (V215) (mounted just above motor coupling right hand side of trap) or broken target stop finger spring. When replacing or adjusting stop finger, it should be positioned to project  $7/32$ " (one-half height of target rim) and almost touching carrier when carrier is in cocked (rear) position. To do this, loosen bolts in stop bracket (V216W) and swing bracket to proper position about  $1/32$ " from edge of carrier and retighten bolts.

continued . . . . .

If stop finger is too low, shim up with washers. Note that when stop finger is properly adjusted, target is not held rigid when resting on carrier plate, but can be moved slightly. This movement is necessary, however, excess movement will cause variation in flight of target (right or left.)

- F. Check for loose target feed shelf bolts, projecting above top of target feed shelf (V203W).
- G. Check height of target feed shelf (V203W). When carrier is in cocked (rear) position, the feed shelf should be flush or slightly below level of carrier plate (V28). A tendency for targets to jump over stops can be corrected by removing shims under feed shelf so that top of shelf is 1/32" (thickness of one shim) lower than carrier plate. Under normal wear conditions, the target feed shelf (V203W) will gradually get higher and require removal of one of the shims (V206) from under the feed shelf. When all shims have been removed and feed shelf is still high, replace target feed arm assembly (V190W) and target feed cam roll (V192W). Before adjusting target feed shelf (V203W) check for bent carrier plate (V28). This plate should be level or slightly lower on the leading edge. If bent, it can be straightened by releasing carrier and supporting carrier arm (V27) with one hand while moving leading edge of carrier plate (V28) up or down. If carrier plate is badly bent, replace.

NOTE: If removal of shims positions top of target feed shelf more than 9/32" below bottom of rear magazine guide rail (V17) (when carrier is in forward position,) replace shims and obtain correct relationship of feed shelf and carrier plate by springing the carrier arm (V27) upward.

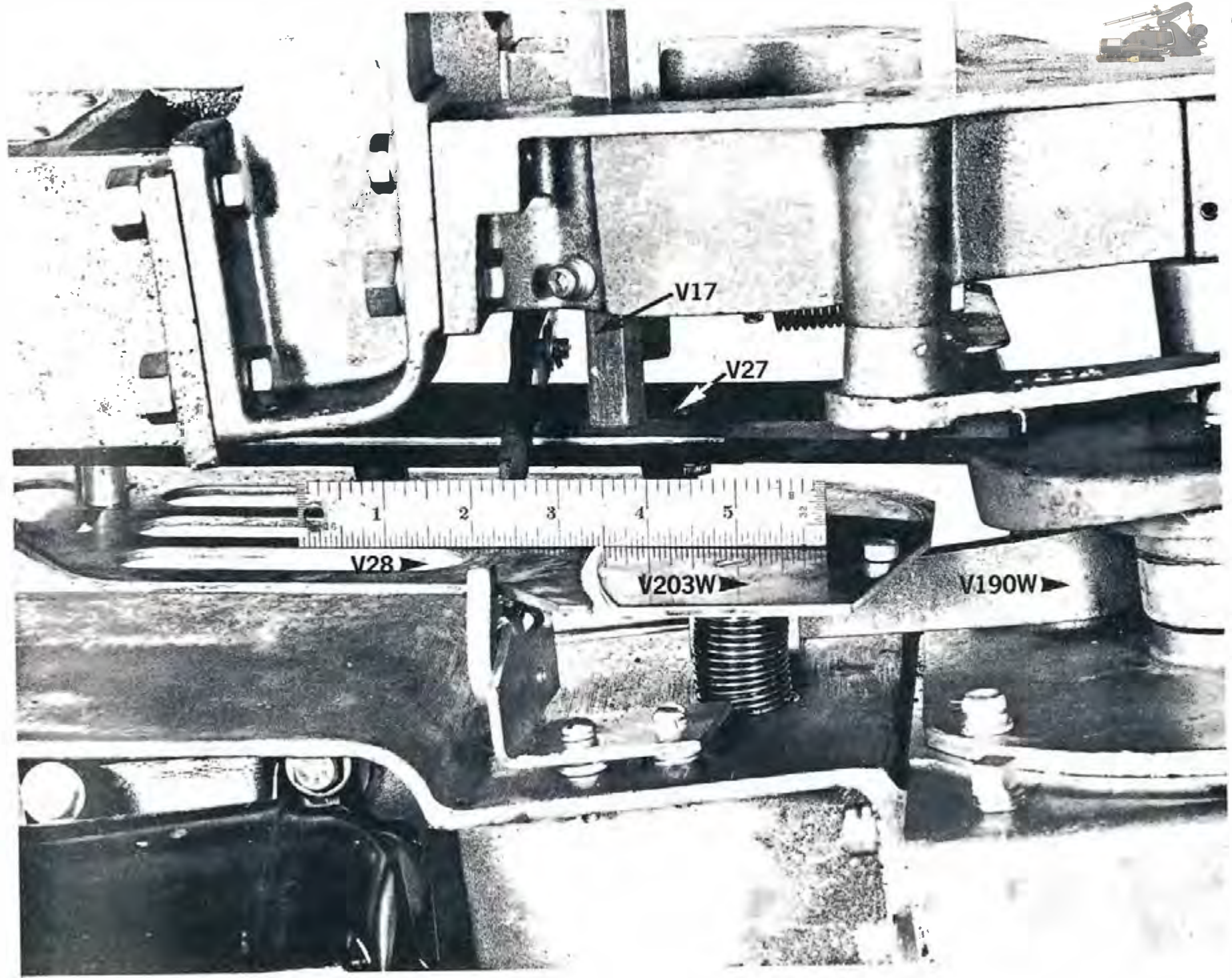

**PROBLEM:** Trap throws large percentage of broken targets.

**CORRECTION:**

- A. Check targets being loaded into magazine for cracks or breaks. Instruct people handling cartons of targets of the necessity of careful handling.
- B. Check to be sure pick up birds are not being used.
- C. Check to be sure target is not hitting opening in house or target chute.
- D. Check position of target feed shelf (V203W). When carrier is in cocked (rear) position, the feed shelf should be flush or slightly below level of carrier plate (V28).

**NOTE:** See item "G" under Trap Throws Continuous Broken Targets for detail on target feed shelf adjustment.

- E. Check for badly worn carrier rail assembly (V32W). A worn carrier rail (V32W) may be reversed for further use.



## TARGET FLIGHT AND FLIGHT ADJUSTMENT, SKEET

The distance and height of targets (at target crossing point) are the same for both high and low house.

The target crossing point is a point 18 feet out from station 8 and in line with station 4 and 8. This crossing point should be marked with a short stake or pipe.

1. Target flight.
  - A. The height and direction of target should be within 3 feet horizontally or vertically, of a point 15 feet above the target crossing point.
  - B. The target, in still air, should carry to a distance equivalent, on level ground, to 55 yards from trap house and not exceed 65 yards.
2. Target flight adjustments.
  - A. With suitable setting pole (usually a piece of 2" x 3" cut or marked to correct length) held vertically at crossing point, throw target and note direction of flight. Correct flight direction is obtained by loosening bolts that hold trap to plank and turning trap right or left. Be sure bolts are retightened before throwing additional targets. Master switch should be off and carrier in fired position before making this adjustment.
  - B. The correct height (15 feet above target crossing point) is obtained by turning elevation adjusting crank (V139) at rear of trap.

continued . . . . .

- C. The correct distance is obtained by turning the main spring adjusting screw (X42) at front of trap. Turn clockwise to increase distance, counter clockwise to shorten distance. Be sure master switch is off and carrier in fired position before making this adjustment.
- D. If targets lean or curve to the right, loosen the screws at each end of carrier rail assembly (V32W), move outer end of rail about 1/8" toward leading edge of carrier, and re-tighten screws while supporting carrier with one hand to prevent springing. If targets lean or curve to the left, move rail in opposite direction. Recheck direction of target flight and correct if necessary.
- E. If considerable variation is noted in direction of target flight, check for worn rubber on carrier rail assembly (V32W). A worn carrier rail may be reversed for further use. Also check for excessive movement of target when carrier is cocked and target in position to be thrown. Excessive movement may be reduced by moving target stop finger (V215) closer to carrier. To do this, turn off main switch and release carrier, loosen bolts in stop bracket (V216W), and swivel bracket so that stop finger (V215) will be closer to the carrier when carrier is in cocked position.

NOTE: Target must have some play for proper operation.

OILING (See Page 19 for Illustrations.)

- A. At time of installation, gear housing (V3W) was filled with one quart of automatic transmission fluid, type A. Each three months, check oil level by removing level gauge plug from raised pad on right side of housing (this is the upper plug on side of housing.)

Add automatic transmission fluid, type A (obtainable from automobile service stations) to bring oil level to this opening. Oil is added by removing filling plug (X133) from top right rear corner of housing and pouring in. This fluid is compounded for year-round use and should not require changing. However, drain plugs are provided on lower right side of gear housing, for use in event housing is to be drained for repairs. Use care to prevent entrance of dirt when any of these plugs are removed.

- B. Periodically (with constant use once a month) squirt a few drops of oil on the following:
1. On the tip of target stop finger (V215).
  2. On the feed shelf guide rods (V198). These are the two rods under target feed shelf (V203W).
  3. On the socket in main spring housing (V5) just above the swivel (X43).

continued . . . . .

4. On the rear threaded end of elevation adjusting screw (V137W) and where the hub of crank (V139), or spring, bears on the hexagon bushing at upper end.
5. On the target feed roll assembly (V192W) of target feed arm assembly (V190W).
6. On the pivot bearing of escapement lever assembly (V50W).
7. On the target escapement cam (V46).
8. On the bearing at rear end of main spring (V40W).
9. A little cup grease should be applied to the bottom surface of target feed cam assembly (V207AW).
10. Once each year (or each 2,000 hours of operation) add 30 to 70 drops of No. 20 SAE motor oil to oil cups on motor.

**NOTE:** When oiling, do not use an excessive amount of oil, as it will collect dust and dirt from targets. Oil sparingly and wipe off excess. Under certain very dusty or sand conditions, it may be advisable to use a dry lubricant in place of oil.



OILING SEE PAGES 17 AND 18

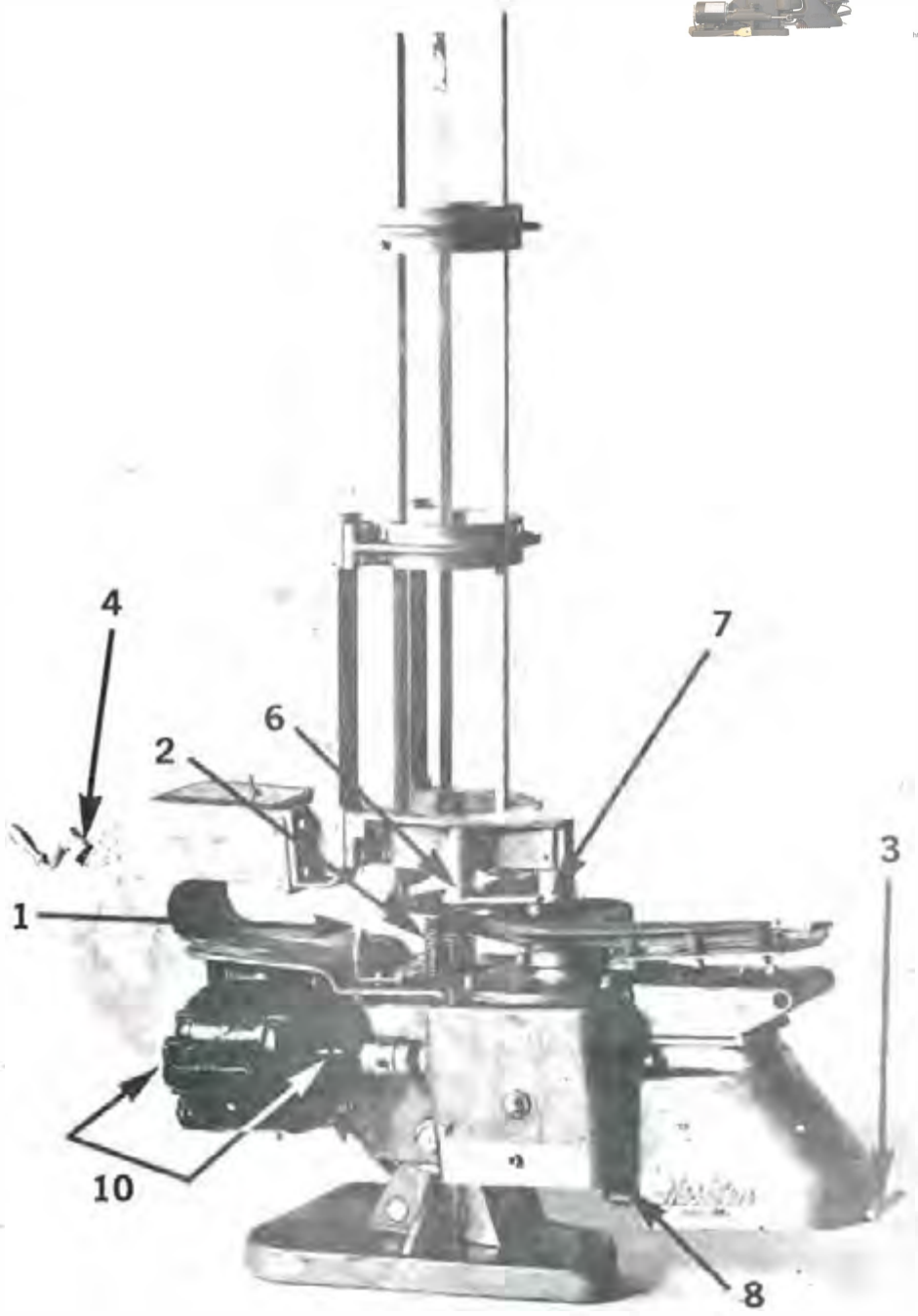
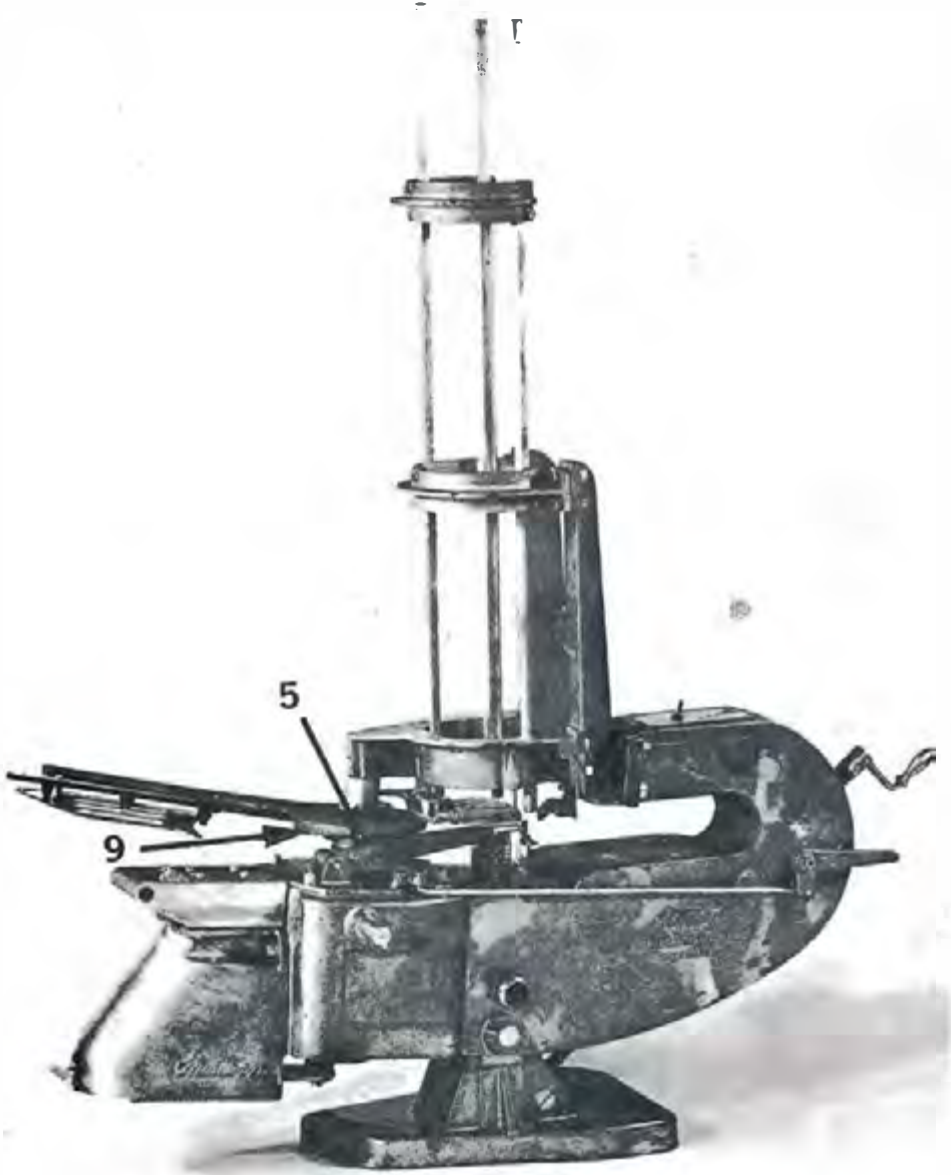

WESTERN SELF-LOADING ELECTRIC SKEET TRAP V1574A

<u>Cat. No.</u>	<u>Name</u>	<u>Cat. No.</u>	<u>Name</u>
V1	Base	V17	Rear Magazine Guide Rail
V2W	Frame Assembly	V18	Front Magazine Guide Rail
V3W	Gear Housing Assembly	V19W	Magazine Guide Rail Screws (Set of 3)
V4W	Gear Housing Cover and Feed Cam Assembly	V23W	Magazine Stabilizer Assembly
V5	Mainspring Housing	V24	Magazine Stabilizer Spring
V6	Solenoid Housing	V27	Carrier Arm
V7	Cocking Pawl	V28	Carrier Plate
V8	Hold-back Pawl	V28W	Carrier Assembly Complete (not shown but including items V27, V28, V29W, V32W, V34 and V35W)
V9W	Control Cam Assembly	V29W	Carrier Plate Screws (Set of 3)
V10W	Sear Assembly	V32W	Carrier Rail Assembly
V11W	Trigger Arm Assembly	V34	Carrier Rail Support
V13R	Magazine Support, Right Hand	V35W	Rail Nut Anchor with Set of Carrier Rail Bolts
V13L	Magazine Support, Left Hand	V36W	Trap grounding bolt (not shown)
V14W	Lower Magazine Bracket Assembly		
V15	Intermediate Magazine Bracket		
V16	Upper Magazine Bracket		

V1574A

Western Self-Loading *Electric* Skeet Trap Parts

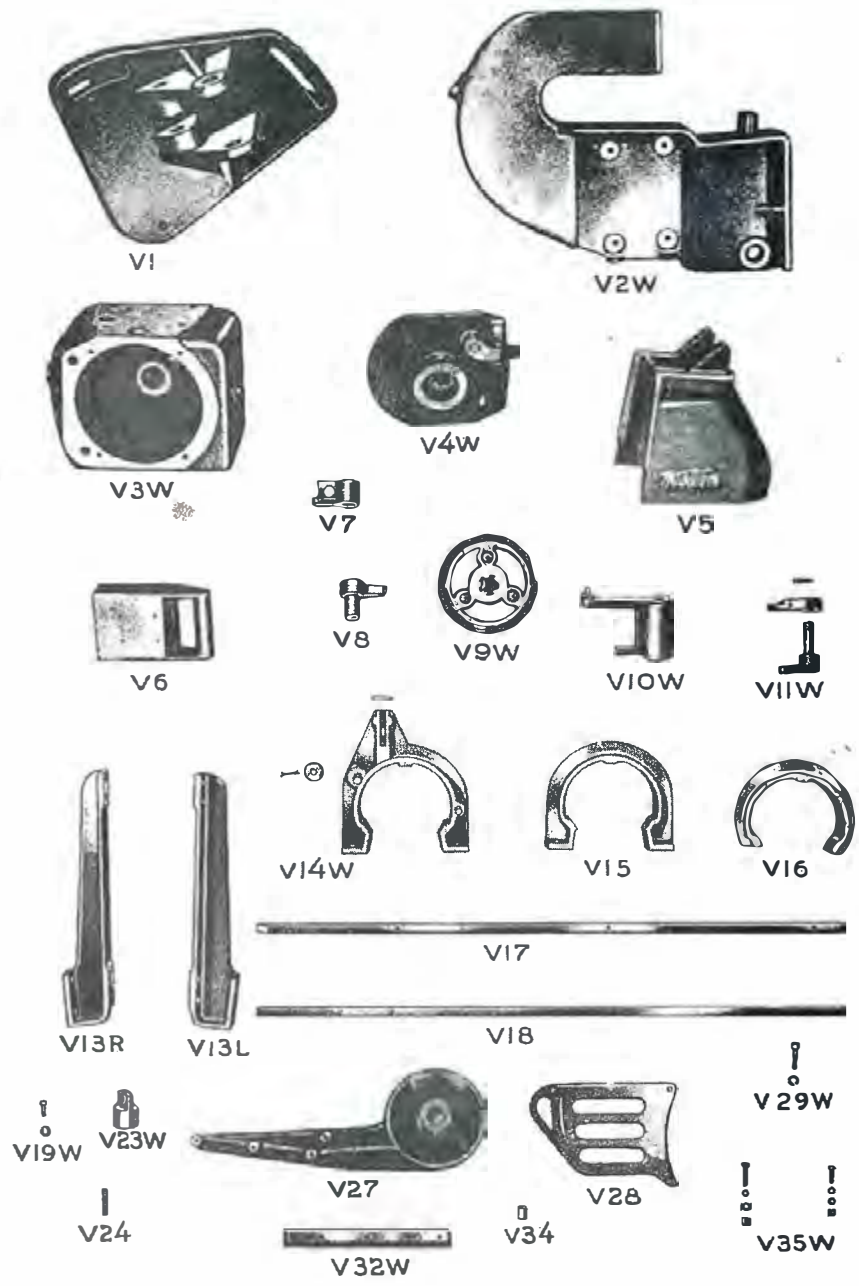

WESTERN SELF-LOADING ELECTRIC SKEET TRAP V1574A



<u>Cat. No.</u>	<u>Name</u>	<u>Cat. No.</u>	<u>Name</u>
X36W	Worm Shaft Gland Assembly	V70	Sear Plunger
X37	Washer for Crank Stud and Escapement Stud	V71	Sear Spring
X39W	Mainspring Crank Assembly	V72	Sear Plunger Bushing
V40W	Mainspring Assembly	X76W	Cable Anchor Clip Assem
X42	Mainspring Adjusting Screw	V79W	Base Bolts (Set of 3 Bolts with Washers)
X43	Mainspring Swivel	X82W	Solenoid Mounting Bolts (Set of 4)
V45	Main Shaft	V84W	Switch Indicator Plate Assembly
V46	Target Escapement Cam	X87W	Screws for Gear Housing Cover or Worm Shaft Gland (Also used to pull V62 Shafts from Housing)(Set of 4)
V47W	Escapement Cam Roll Assembly	X88W	Clamp Screw Assembly for Mainspring Crank
V49	Retaining Washer for Items V47W, V209 and V215	V91W	Magazine Support Screws (Set of 2)
V50W	Escapement Lever Assembly	V92W	Magazine Bracket Bolts (Set of 2)
V51A	Escapement Lever Spring	V93W	Gear Housing Mounting Screws (Set of 4)
V52B	Escapement Cushion	X94	Key for Mainspring Crank
V57	Trigger	V105W	Main Shaft Oil Seal and Lower Bearing Assembly
V58	Trigger Pull Rod	X106	Worm Shaft Oil Seal
X58	Trigger Arm Spring	V107	Driving Worm
V59W	Trigger Mounting Bolt Assembly	V108W	Worm Gear Assembly
V60	Trigger Bushing	V110W	Planet Gear Assembly
V62	Shaft for Sear and Hold-Back Pawl	V111	Ring Gear and Ratchet
V63W	Pawl Holding Magnet Assembly	X116W	Master Switch
X65	Cocking Pawl Spring	V118A	Power Cord Assembly
V66	Firing Pin	V120A	Power Receptacle
V67	Firing Pin Guide		
V68	Firing Bar		

\* A used V40W Mainspring Assembly may be returned to the factory for reconditioning with new spring and bushing.

(Note that the V40W Mainsprings are distinguished from the lighter X40W Mainsprings, listed elsewhere, by a number stamped on end of the adjusting screw plug.)

V1574A

Western Self-Loading *Electric* Skeet Trap Parts

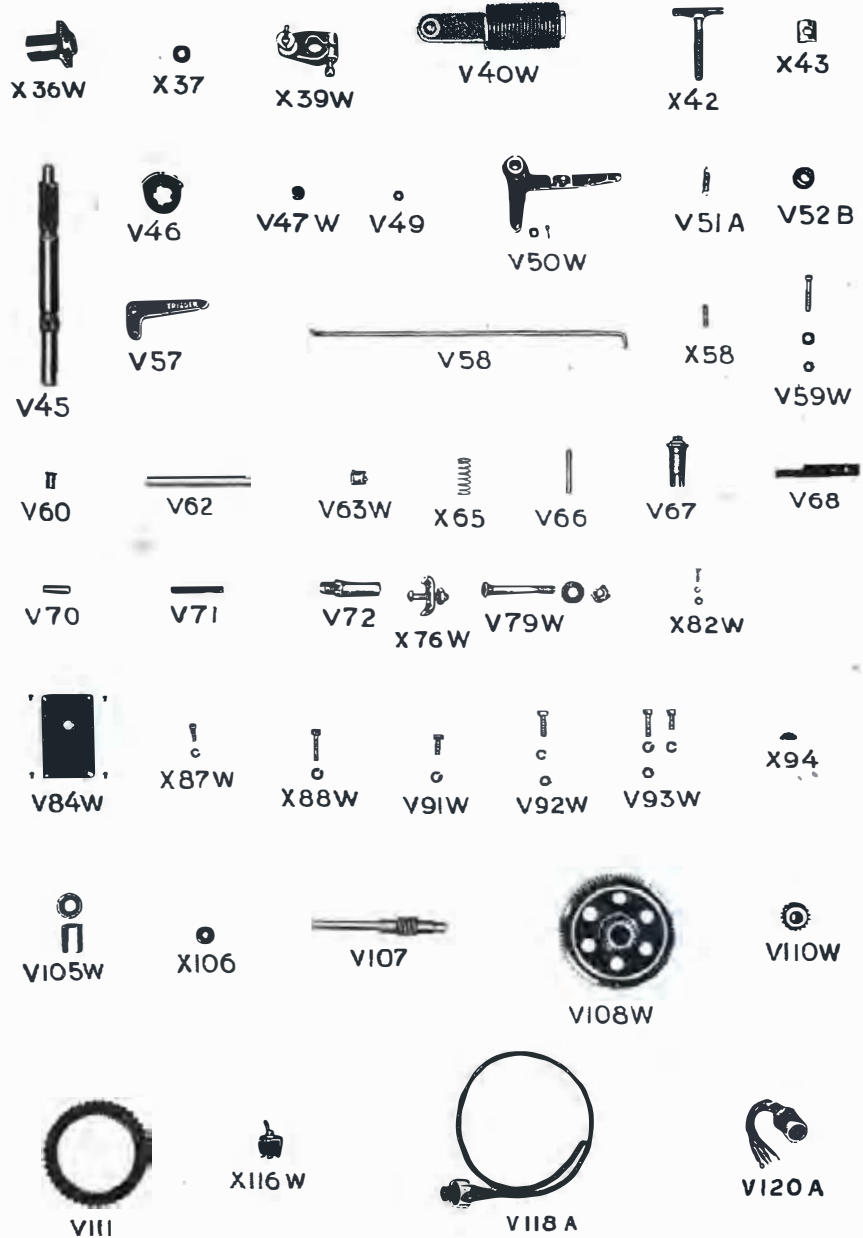



WESTERN SELF-LOADING ELECTRIC SKEET TRAP V1574A

<u>Cat. No.</u>	<u>Name</u>	<u>Cat. No.</u>	<u>Name</u>
V125	Field Cable	X176	Ground Rod Clamp (not shown)
V126W	Outlet Box Assembly	V190W	Target Feed Arm Assembly
V128	Squeeze Type Two-Screw Connector	V191W	Target Feed Arm Pivot Assembly
X127	Release Solenoid	V192W	Target Feed Cam Roll Assembly
X129A	Motor	V194W	Feed Shelf Operating Roll Assembly
X130B	Motor Coupling	V196W	Feed Shelf Lifting Springs (Set of 2)
X132	Worm Thrust Bearing	V197W	Feed Shelf Operating Bracket Assembly
X133	Oil Filler, Drain and Level Gage Plugs, Each	V203W	Target Feed Shelf Assembly
V134W	Assorted Cotter Pins (not shown)	V205W	Target Feed Shelf Bolts (Set of 2)
V135W	Elevation Pivot Assembly	V206	Feed Shelf Shim (1/32" thick)
V136	Elevation Screw Swivel	V207AW	Target Feed Cam Assembly
V137AW	Elevation Adjusting Screw Assembly	V209A	Target Feed Finger
V141W	Tool for Guiding Main Shaft through Oil Seal	V210AW	Feed Finger Bracket Assembly
V151W	Escapement Cushion Assembly	V214	Spring for Target Feed and Stop Fingers
V155AW	Escapement Carrier Base Assembly	V215	Target Stop Finger
V157W	Escapement Cushion Cover Assembly	V216W	Stop Finger Bracket Assembly (with Bolts)
V160W	Escapement Cushion Cover Screws (Set of 2)	X190W	Stop Finger Bracket Bolts only (Set of 2)
V161W	Solenoid Housing Screws (Set of 2)		(not shown)
V163W	Motor Mounting Bolts (Set of 4)		
V173W	Motor Support Screws (Set of 2)		
X175	Ground Rod (not shown)		

V1574A

Western Self-Loading *Electric* Skeet Trap Parts

